



User's Manual

ARTUS-701ES



Safety precautions are intended to protect the user's safety and prevent property damage. Please read the instructions before use and use them correctly.

Contents

Chapter 1. Warning and Caution

- 1.1 Warning
- 1.2 Caution
- 1.3 Information of Electro-Magnetic Compatibility (EMC)

Chapter 2. Product

- 2.1 Introduction of ARTUS-701ES
- 2.2 Operation
- 2.3 Purpose of ARTUS-701ES
- 2.4 Before reading the user manual
- 2.5 Safety Precaution
- 2.6 Caution
- 2.7 Damaged product during delivery
- 2.8 Product Configuration
- 2.9 Label
- 2.10 Component name
- 2.11 Product specifications
- 2.12 Setting

Chapter 3. Explanation of Terms and Symbols

- 3.1 Explanation of Terms
- 3.2 Explanation of Symbols

Chapter 4. Installation

Chapter 5. Operation

- 5.1 How to adjust the device according to the exercise
- 5.2 How to use Hand Controller and set the exercise

Chapter 6. Maintenance and Troubleshooting

- 6.1 Storage Conditions
- 6.2 Treatment and Maintenance
- 6.3 Troubleshooting

Chapter 7. Warranty

Thank you for purchasing the Shoulder CPM(ARTUS-701ES).

Please refer to the manual in the box to view the components contained within the box when opening the box.

Be sure to familiarize yourself with this manual before connecting and powering down the parts, and keep the manuals handy for future use.

The illustrations in this manual may differ slightly from the originals.

Chapter 1. Warning and Caution

Safety precautions are intended to be used safely and correctly to prevent accidents or risks, so please ensure that you read and protect them carefully.

Cautions are divided into 'warning' and 'caution', each meaning :



Warning : If there is a possibility of death or serious injury to the person in violation of the instructions



Caution : Violation of damaged products or possible minor injury to the human body when violating the instructions.

1.1 Warning

- Please check the power during installation and using.
Violation of this range could cause electric shock and product would be damaged.
- Please check the wiring of all terminals before turning on the power.
This could cause electric shock and malfunction.
- Please do not use it with wet hands.
This could cause electric shock and malfunction.
- Please do not change or extend the power cable arbitrarily.
This could cause fires and electric shock.
- Please program the range of motion as prescribed by a physician.
This could cause deterioration in affected area and injury.
- Please do not place the product near the fire.
This could cause fires.
- If there are any unusual sounds, smells and smoke from the product, please turn off the main power switch. This could cause a fires and failure.
- Please make sure to be careful of water inside the product.
This could cause fires and failure.
- Please do not dismantle, repair and remodel arbitrarily.
This could cause fires and electric shock
- Please do not keep the product with combustible substance and inflammability gas.
This could cause a fires and failure.
- Please do not use the product in gas spill area.
This could cause fires and explosion.
- Please turn off the power switch during cleaning.
This could cause fires and electric shock.

1.2 Caution

- Please do not disconnect the power or communication cables during operating.
This could cause injury.
- Elderly people and people with disabilities should use it under supervision of product manager such as doctor or physical therapist.
This could cause injury.
- Please do not install the product on unsafe place.
This could cause injury.
- Please do not dismantle the product arbitrarily.
This could cause fires and failure.
- Please do not allow any metallic foreign substance to enter the inside of the product.
This could cause fires and failure.
- Please connect the earth terminal.
This could cause electric shock, malfunction and failure.
- Please clean the product with soft cloth and do not use strong cleanser like solvent.
This cause fires and deformation.
- Please do not tap with anything sharp or use excessive force to the screen when using the hand controller. This could cause damage the screen or malfunction.
- Please check the tightening a bolt before operating.
This could cause injury.
- Please avoid sharp object when installing and opening the product.
This could cause product damage.
- Please make sure that a part of body or clothing gets caught to device during operating.
This could cause injury.
- Please do not use except for rehabilitation treatment purposes.
This could cause failure and injury.
- When you disconnect the power plug or hand controller, please hold the plug and do not hold the cable.
This could cause electric shock and product damage.
- Please disconnect the power plug from the socket before moving.
This could cause electric shock and product damage.
- Please do not exercise too much.
This could cause injury of joints.

1.3 Information of Electro-Magnetic Compatibility (EMC)

- Warning : Please note that emitted electromagnetic signals from the external environment may affect the patient and also ARTUS-701ES.
- Warning : Do not use ARTUS-701ES near high-power wireless equipment such as mobile phone, this could cause malfunction.
- Caution : ARTUS-701ES is compliant with medical device regulations 93 / 42 / EEC and it is designed to protect it from electromagnetic signals.
- Caution : Portable and mobile frequency (RF) communication device may affect the electronic medical devices.
- Caution : Only the component we provide are recommended to use, other unspecified devices may cause increasing emissions and immunocompromised status.

The RF of “ARTUS-701ES” emissions are very low and are not likely to cause interference in nearby electronic equipment.

The “ARTUS-701ES” is suitable for use in all establishments other than domestic and those directly connected to the public low voltage power supply network that supplies buildings used for domestic purposes.

Mains (AC) power quality should be that of a typical commercial or hospital environments.

Floors should be wood, concrete or ceramic tile. If floor is covered with synthetic material, the relative humidity should be at least 30% to avoid excessive static electricity.



Warning : The “ARTUS-701ES” should not be situated adjacent to, or stacked with, other electronic equipment. If the system must be installed in close proximity to other equipment, both the “ARTUS-701ES” and the nearby equipment should be observed to verify normal operating in that configuration.



Caution : The “ARTUS-701ES” has been designed to meet the standards of IEC60601-1-2 for electromagnetic compatibility; however some computer equipment unintentionally emits strong interfering RF signals. Portable RF communication devices may also affect “ARTUS-701ES”.



Warning : Use of accessories other than those specified, may result in increased emissions, or decreased immunity of this system.

Chapter 2. Product

2.1 Introduction of ARTUS-701ES

Thank you for purchasing ARTUS-701ES.

ARTUS-701ES is a rehabilitative exercise equipment (Continuous Passive Motion Machine) that recovers the lost function of Shoulder joint quickly through the continuous passive motion for patient who cannot exercise by themselves. It can also be adjusted angle range of exercise, exercise time, the number of exercise, etc. And also it is available to set 5 steps exercising speed. Acceleration mode allows the exercise speed up to 2 steps faster than previously programmed speed. It also provide a caster to move product easily.

Hand Controller(H/C) which is adopting 3.5 inch screen and touch is easy to operate and it provides the information of progressing and programing exercise on screen.

2.2 Operation

If it is left untreated after the shoulder joint surgery, it may cause problems such as limited range of motion and muscle contraction. And applying too much load to the shoulder joint without rehabilitation may worsen the condition of the surgical area. So it is necessary to exercise properly for the quick recovery of surgical area. ARTUS-701ES is the rehabilitation equipment to recover the function of shoulder joint quickly through continuous passive movement.

Range of motion is different depending on the exercise mode and exercising ROM has to be programmed according to the condition of patient.

Please exercise at a slow speed at first, and then do exercise higher speed and wider angle after becoming familiar with the equipment. Exercise with a wide range of motion from the beginning could cause secondary damage to the patient's surgical site.



<FIG 2.1 ARTUS-701ES>

2.3 Purpose of ARTUS-701ES

- ARTUS-701ES is a rehabilitative exercise equipment that recovers the lost function of shoulder joint quickly through continuous passive motion for patient who cannot exercise by themselves at equipped such as hospitals.
- The ARTUS-701ES should be used in a properly equipped environment such as a hospital and must be handled by trained professional who have the proper qualifications like physical therapists or medical specialists.

2.4 Before reading the user manual

- Please read the user's manual before using ARTUS-701ES.
- The user's manual is for buyer and user, it will help to use the product safely.
- The user's manual is for using the product to ensure safe and proper use.
- The user's manual could be revised any time at the manufacturer's discretion.

2.5 Safety Precaution

- ARTUS-701ES uses the power of AC100V ~ 240V, 50 / 60Hz.
- Please check the power when using it inside.
- The product should be used while the room is at room temperature.
- Please be well-informed of the user manual before using.

2.6 Caution





- Please use the product as prescribed and do not stab the hand controller with anything sharp.

2.7 Damaged product during delivery

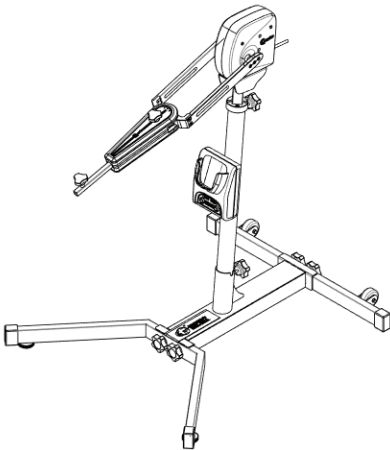
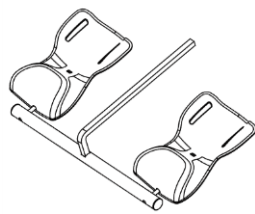

- ARTUS-701ES will be shipped securely in an outer box with inner packing.
- After receiving the product, please check for damage or something abnormal on product.
- If any damage or abnormality is found, contact the company that purchased the product.

2.8 Product Configuration

- Please check the product and accessories before installation.

 <p>Body</p>	 <p>Hand Splint</p>	 <p>Upper Arm Splinter</p>
	 <p>Hand Controller</p>	 <p>Power Cable</p>

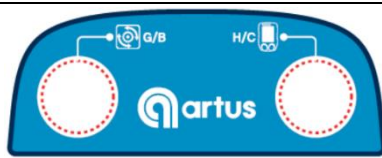
2.9 Label

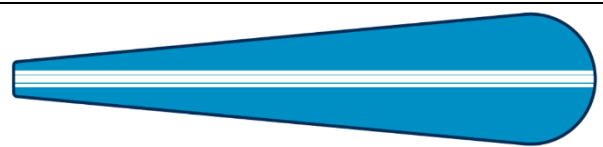
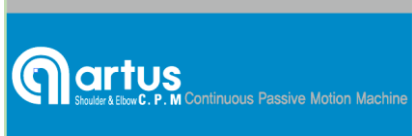
HC label	
Control box label	
Elbow label (Upper)	
Elbow label (Bottom)	
Base label	

2.10 Component name

- Main device

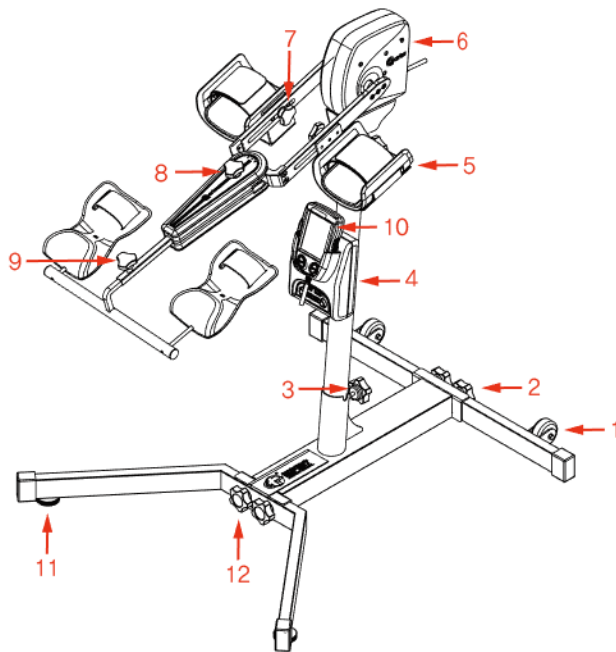

1. Caster
2. Rear lower assembly locking screw
3. Height adjustment part locking screw
4. Control box
5. Upper arm splinter
6. Shoulder motor
7. Upper arm splinter locking screw
8. Angle adjustment locking screw
9. Hand splinter and lower arm length adjustment locking screw
10. Hand controller
11. Balancing screw
12. Front lower assembly lock

- Hand Controller

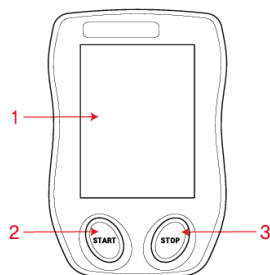

1. Touch Screen
2. Start Button
3. Stop Button

- Control box

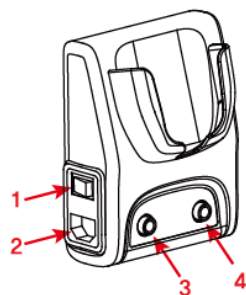

1. Power Switch
2. Power inlet
3. Connector to motor
4. Connector to Hand Controller

2.11 Product specifications

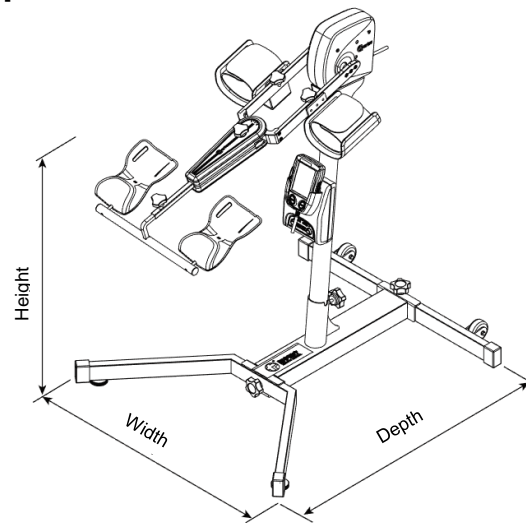

Division	Contents
Type of Protection	Class I, Type B
Rated Power	AC 100V~240V, 50/60Hz
Power Consumption	30VA
Operating Temperature / Humidity	+10°C ~ +40°C / 80% or less
Storage Temperature	0°C ~ +60°C
Atmospheric Pressure	700~1060 hPa
Size	670 X 790 X 910 (Width X Length X Height)
Weight	13.5 kg

2.12 Setting





Division	Flexion / Extension	Abduction / Adduction
Lower limit ~ Upper limit	20° ~ 180°	20° ~ 160°
Speed	1~6 steps (48° ~ 150°/min)	
Pause	0~99 sec	
Timer	1~99 min	
Counter	1~99	

Chapter 3. Explanation of Terms and Symbols

3.1 Explanation of Terms

Term	Explanation
Upper limit	Limit angle of flexion and abduction of shoulder Limit angle of flexion of elbow Limit angle of inner rotation of Elbow
Lower limit	Limit angle of extension and adduction of shoulder Limit angle of extension of elbow Limit angle of outer rotation of Elbow
Upper pause	Pause time at Upper limit angle
Lower pause	Pause time at Lower limit angle
Bypass	The function of adjusting upper and lower limit angle during exercise operating
Manual	The function to check manually the patient's available exercising ROM before exercise operating
Speed/Uni/Accel	Exercise speed level / Uniform speed / Accelerated speed
Timer	Time of Exercise
Counter	Number of Exercise
M1	The exercising motor for Shoulder

3.2 Explanation of Symbols

Symbol	Explanation	Symbol	Explanation
	Exercise mode of Flexion/Extension of shoulder		Exercise mode of Abduction/Adduction of shoulder
	Increment / Decrement		Display of device operating status
	Touch locked		

Chapter 4. Installation

Refer to clause 2.8 Product configuration.

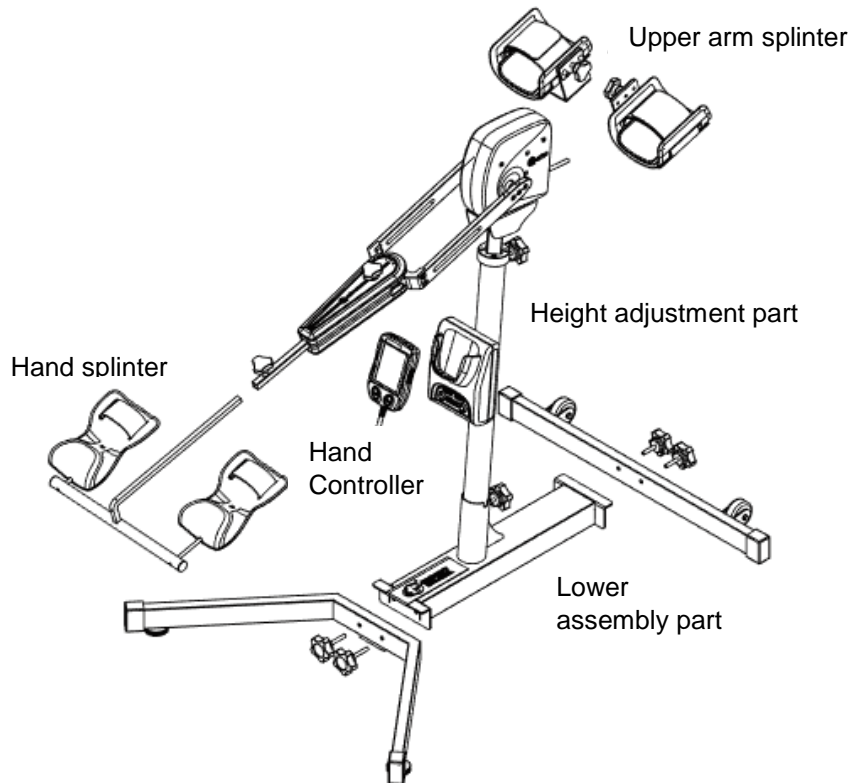

- Step 1. Fix the lower assembly part.
- Step 2. Mount and fix the Height adjustment part
- Step 3. Mount and fix Hand splinter
- Step 4. Mount upper arm splinter
- Step 5. Connect the hand controller and motor cables to the control box.



Warning : Tighten the fixing screw (knob) firmly to prevent the device from separation during exercise.

Chapter 5. Operation

- Please review warning and caution in Chapter 1.
- Please check the connection of the power switch (cord) and the hand controller.
- Explanation of symbols in the control unit is covered in Chapter 3.

5.1 How to adjust the device according to the exercise



Warning : Tighten the fixing screw (knob) firmly to prevent the device from separation during exercise

5.1.1 Device adjustment for Flexion/Extension

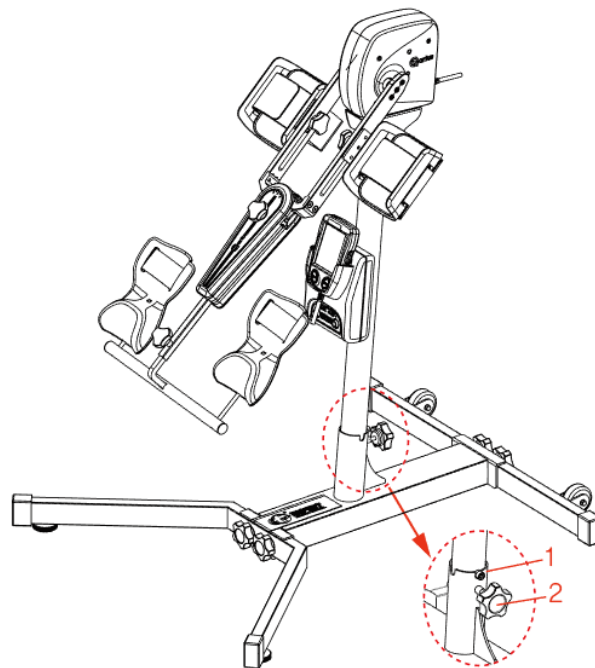

<Fig 5.1.1>

- Step 1. Set the Shoulder motor and hand splinter to face forward.
- Step 2. At this time, make sure that the direction guide tip(1) on the bottom of height adjustment is facing backward.
(Align with the groove on the lower assembly part)
- Step 3. Fix with height adjustment locking screw(2).



Warning : Tighten the fixing screw (knob) firmly to prevent the device from separation during exercise.

5.1.2 Device adjustment for Abduction/Adduction

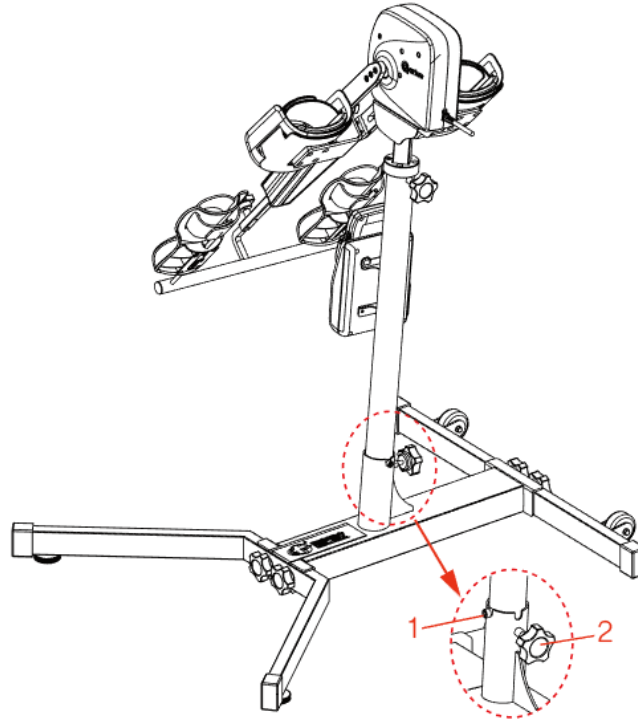

<Fig 5.1.2>

- Step 1. Set the Shoulder motor and hand splinter to face forward.
If the lesion is the right shoulder, it should be on the right side,
and if the lesion is on the left shoulder, face the left side
- Step 2. At this time, make sure that the direction guide tip(1) on the bottom of
height
adjustment is facing side.
(Align with the groove on the lower assembly part)
- Step 3. Fix with height adjustment locking screw(2).



Warning : Tighten the fixing screw (knob) firmly to prevent the device from separation during exercise.

5.1.3 Adjustment the arm length

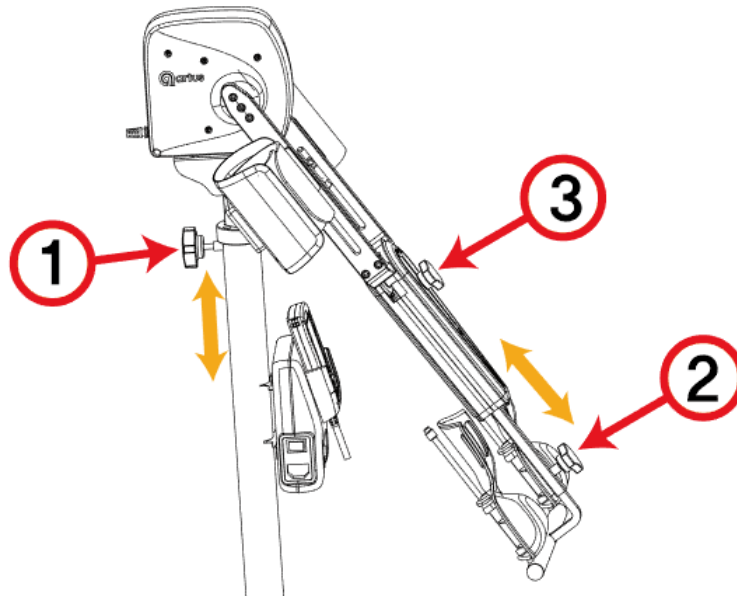

<Fig 5.1.3>

- Step 1. A patient is sitting comfortably in the separate chair and has his back tightly attached to the chair back
- Step 2. Adjust the location of Shoulder motor to the patient's shoulder.
- Step 3. Loosen the shoulder height adjustment screw (1), and adjust the height of the axis of Shoulder motor to fit to the patient's shoulder.
And then tighten the screw to fix it.
- Step 4. Loosen the lower arm length adjustment screw(2), and adjust the length of the Hand splinter to fit to the length of patient's arm.
And then tighten the screw to fix it.
- Step 5. Loosen the elbow angle adjustment locking screw(3), and adjust the patient's elbow angle to feel comfortable during exercise.
And then tighten the screw to fix it.



Warning : Tighten the fixing screw (knob) firmly to prevent the device from separation during exercise.

5.2 How to use Hand Controller and set the exercise

5.2.1 Explanation of full screen

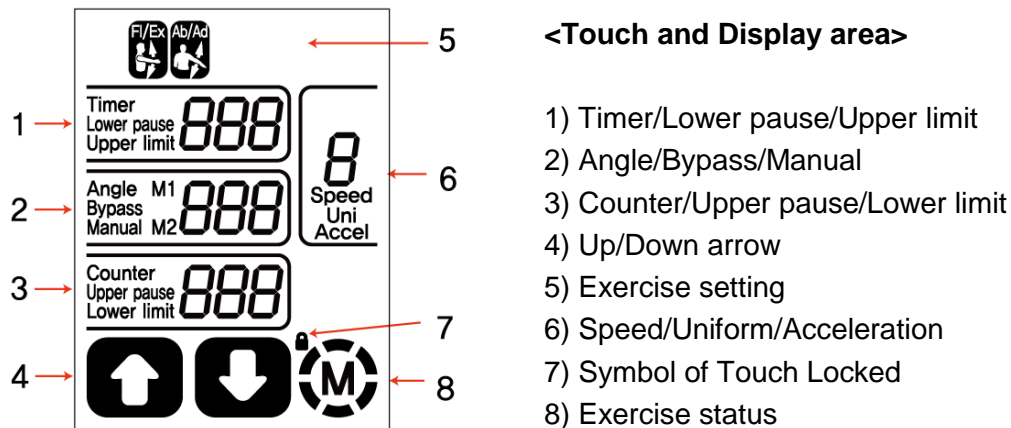

● Function of each area

1) [Timer / Lower pause / Upper limit] area

Touch this area to set the exercising time, pause time at the lower limit angle and upper limit angle to exercise.

Upper limit angle means that the angle of Flexion, Abduction and inner Rotation to exercise.

2) [Angle / Bypass / Manual] area

Touch this area to set Bypass, Manual function and display current exercising angle.

3) [Counter / Upper pause / Lower limit] area

Touch this area to set the number of exercising, pause time at the upper limit angle and lower limit angle to exercise.

Lower limit angle means that the angle of Extension, Adduction and outer Rotation to exercise.

4) [Up arrow / Down arrow] area

Touch this area to change a setting value and select a function.

5) [Exercise setting] area

Press and hold this area for 2 seconds to set the exercise according to connection of motor.

Touch this area to select a setting mode of M1 and M2, the selected motor is displayed in [Angle/Bypass/Manual] display area.

6) [Speed / Uniform / Acceleration] area

Touch this area to set the exercising speed level and uniform or accelerative exercising mode.

7) [Touch Locked] symbol

This symbol means touch function being locked.

8) [M] symbol

Touch this area to save the set value and return to the previous screen at setting mode, and it

display exercise operating(circle of M is circulating) mode or stop mode.

5.2.2 Set the Exercise

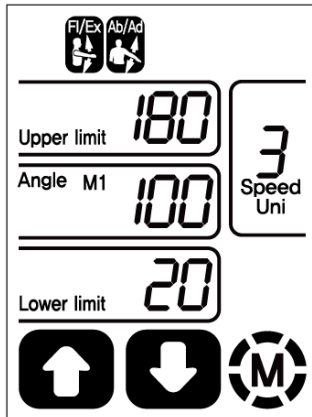

: Flexion / Extension of Shoulder



: Abduction / Adduction of Shoulder

- 1) To set desired exercise, It must be connected shoulder motor to do exercise.
The exercise of Flexion/Extension and Abduction/Adduction are available.
- 2) Press and hold [Exercise setting] display area for 2 seconds to set the exercise, when the exercise symbol is flickering, select exercise using [Up/Down] arrow.
- 3) After selection of exercise, touch the [M] to save setting data.

5.2.3 Set the range of exercise and Pause time

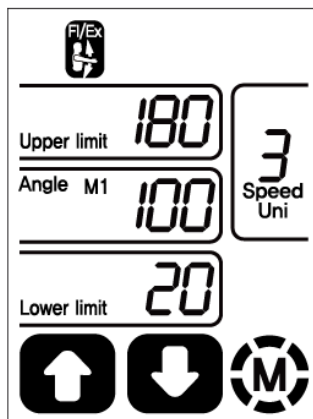

※ The name of each touch area refer to clause 5.2.1.

- 1) Upper limit (angle) and Lower limit (angle)
 - It means exercise range to do an exercise.
 - Touch the [Upper limit] display area(1), and select upper limit (angle) with [Up/Down] arrow(4) when the number is flickering.
 - Touch the [Lower limit] display area(3), and select lower limit (angle) with [Up/Down] arrow(4) when the number is flickering.
 - And then, touch the symbol [M](8) to complete setting of limit angle.
- 2) Upper pause (time) and Lower pause (time)
 - It is the exercise pause time at the upper or lower limit angle.

- [Upper pause] will be displayed when touched twice the [Lower limit] display area(3), and select upper pause (time) with [Up/Down] arrow(4) when the number is flickering.
- [Lower pause] will be displayed when touched twice the [Upper limit] display area(1), and select lower pause (time) with [Up/Down] arrow(4) when the number is flickering.
- And then, touch the symbol [M](8) to complete setting of pause time.

5.2.4 Set the Exercising Speed and Uniform or Accelerative exercising

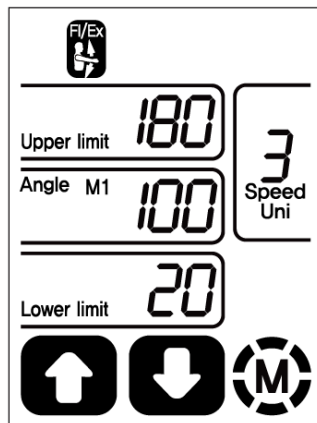

※ The name of each touch area refer to clause 5.2.1.

1) Exercising Speed

- It means operating(moving) speed of device.
- Touch the [Speed] display area(5), and select speed step with [Up/Down] arrow(4) when the number is flickering.
- And then, touch the symbol [M](8) to complete setting of speed step.

2) Uniform(Uni) / Acceleration(Accel) mode

- Uniform(Uni) Mode : The device moves with uniform exercising speed in the ROM.

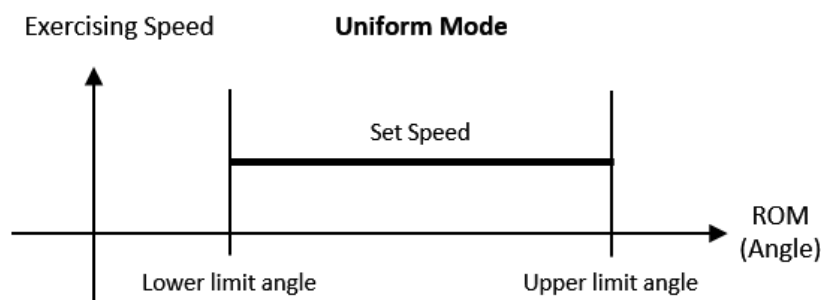

- Acceleration(Accel) Mode : The device moves by two steps faster than the programmed speed in the middle 50% of the range of exercise.

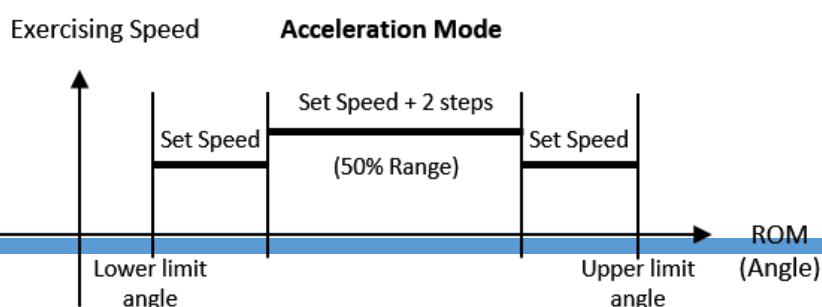

- It is available to select uniform or accelerative exercising speed by touching twice the [Speed] display area(5).
- The current selected mode is flickering and available to change that with [Up/Down] arrow(4).
- And then, touch the symbol [M](8) to complete setting of this.

5.2.5 Set the exercise time and the number of exercise

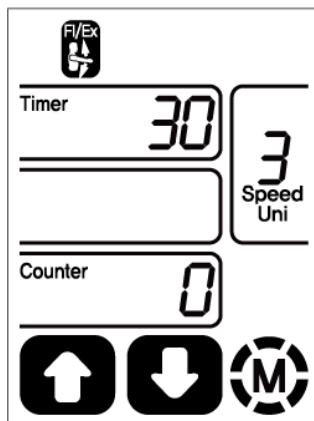

※ The name of each touch area refer to clause 5.2.1.

1) Exercise time

- If touch the symbol [M](8) at the screen of clause 5.2.4, the screen is changed like above.
- Touch the [Timer] display area(1), and change exercise time with [Up/Down] arrow(4).
- And then, touch the symbol [M](8) to complete setting of exercise time.

2) Number of exercise

- Touch the [Counter] display area(3), and change the number of exercise with [Up/Down] arrow(4).
- And then, touch the symbol [M](8) to complete setting of the number of exercise.

5.2.6 Set the function of Bypass and Manual

1) Bypass

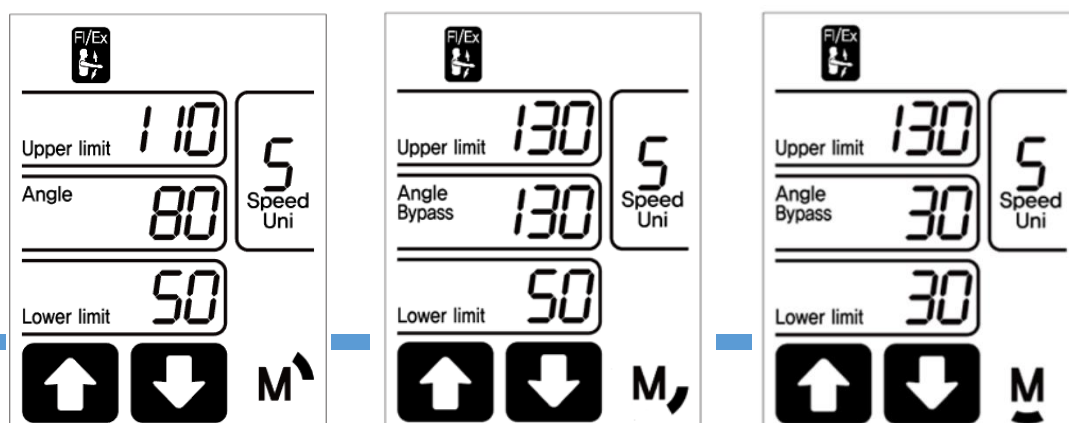

- <Fig 5.2.1> <Fig 5.2.2> <Fig 5.2.3>
- The [Bypass] function is used to adjust exercise range during exercise operating.
 - Touch the [Angle] display area(2) in screen <Fig 5.2.1> while exercise is operating, [Bypass] is displayed like screen <Fig 5.2.2>.
 - When the motion is moving in the direction of [Upper limit] angle, pressing and holding the [Up arrow] can increase current exercising angle over programmed [Upper limit] angle. If it is reached at desired angle, touch [Upper limit] display area(1) to change [Upper limit] angle. The <Fig 5.2.1> shows the changing from 110° to 130°.
 - When the motion is moving in the direction of [Lower limit] angle, pressing and holding the [Down arrow] can decrease current exercising angle over programmed [Lower limit] angle. If it is reached at desired angle, touch [Lower limit] display area(3) to change [Lower limit] angle. The <Fig 5.2.3> shows the changing from 50° to 30°

2) Manual

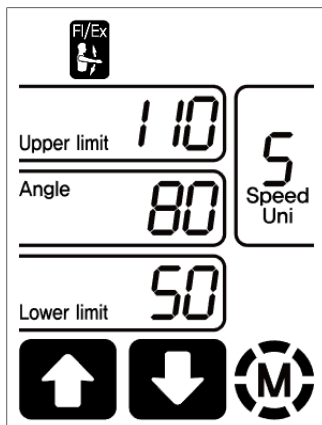
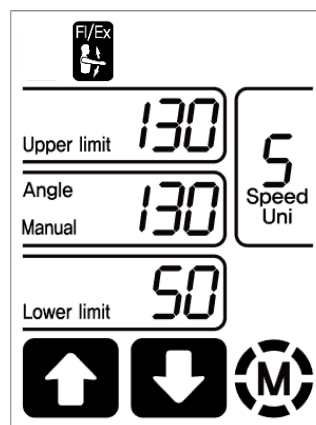
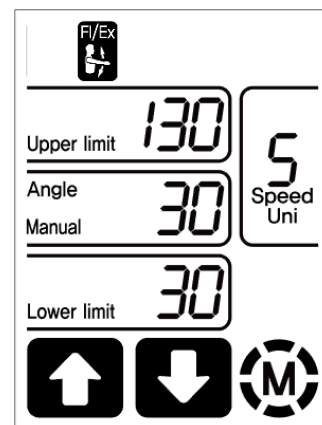

Fig 5.2.4>



<Fig 5.2.5>





<Fig 5.2.6>

- The [Manual] function is used to adjust exercise range at the stop mode.
- Touch the [Angle] display area(2) in screen <Fig 5.2.4> while exercise is stopped, [Manual] is displayed like screen <Fig 5.2.5>.
- Pressing and holding the [Up arrow] increase current angle, if it is reached at desired angle, touch [Upper limit] display area(1) to set as [Upper limit] angle. The <Fig 5.2.5> shows the setting being changed from 110° to 130°.
- Pressing and holding the [Down arrow] decrease current angle, if it is reached at desired angle, touch [Lower limit] display area(3) to set as [Lower limit] angle. The <Fig 5.2.6> shows the setting being changed from 50° to 30°.

5.2.7 Locking a touch function

- It is possible to lock the touch function in order not to change a programmed value by patient.
- Pressing and holding the [STOP] button for 5 seconds in the stop mode, the [Lock]

- function is set with 'beep' sound and  symbol displaying, above screen shows this.
- It is available to operate only [START] and [STOP] button.
 - The [Lock] function is disabled with 'beep' sound and  symbol disappearing by pressing and holding the [STOP] button for 5 seconds.

Chapter 6. Maintenance and Troubleshooting

6.1 Storage conditions

- Please shutdown the main power switch of the product before cleaning.
- Please use a dry cloth while cleaning to protect the inside of the product from liquid.

6.2 Treatment and Maintenance

- Please check the tightness of bolts on a regular basis, at least every six months.
- Please make sure that the cable is not damaged or torn.
- Please make sure that the label is not damaged and is kept to identifiable.

6.3 Troubleshooting

If you encounter any of the following problems during use, please do the following.

NO	Symptoms	Actions
1	The screen of the Hand Controller does not work.	<ol style="list-style-type: none"> 1. Please check the supplying of power. 2. Please check the connection of the Hand Controller with device.
2	The touch function does not respond.(no change/ no sound)	<ol style="list-style-type: none"> 1. Please initialize the Hand Controller. <ul style="list-style-type: none"> - Turn on the power again while pressing and holding both of the [START] and [STOP] buttons. - When a screen is displayed, then touch anywhere on screen. 2. Please check whether Touch Lock function enabled. Refer to clause 5.2.7.
3	Error code 'E1' displayed	<p>The motor is stopped temporary.</p> <ul style="list-style-type: none"> - Please check the cable connection between Hand Controller and Device. - If the Hand Controller cable is disconnected to device, please reconnect the cable after power turn off.
4	Error code 'E2' displayed	<p>Check the Shoulder Motor.</p> <ul style="list-style-type: none"> - Please check the cable connection between Shoulder Motor and Device. - If the Shoulder Motor cable is disconnected to device, please reconnect the cable after power turn off.

5	Error code 'E4' displayed	<p>The current angle of Shoulder Motor is out of programmed range of exercise.</p> <ul style="list-style-type: none"> - Pressing and holding the [START] button for more 3 seconds, then the device goes into the programmed range. <p>The error code will disappeared.</p>
6	Error code 'E4' displayed	<p>The current angle of Shoulder Motor is out of programmed range of exercise.</p> <ul style="list-style-type: none"> - Pressing and holding the [START] button for more 3 seconds, then the device goes into the programmed range. <p>The error code will disappeared.</p>

※ **If the error message continues to appear even though you have taken suggested course of actions from above, you should seek after sale service.**

Chapter 7. Warranty

This product is manufactured through its strict quality control and inspection process. Standard of Compensation for product repair and replacement are that comply with "compensation criteria for consumer's damages" which is announced by Korean Government. The warranty period for this product has been defined as one year. In case of a failure in normal use, we will repair it free of charge during the warranty period at its service center.

If any trouble arises during the warranty, please let us know the model of the product, date of purchase and failure information.

Manufacturer and Distributor(or Agency) are not liable for performance issues or incompatibilities caused by Products neglect or using incorrect.

This product is a technically verified, a problem caused by using a third party's products instead of those supplied components at the time of shipment is regarded as the user's carelessness.



- **This user's manual cannot be changed or reproduced without prior consent of our company.**
- **This user's Manual is subject to change without prior notice.**

Service Information

Developer & Manufacturer :

CST Co., Ltd. 325, Daeyulnaechu-gil, buki-myun, Cheongwon-gu, Cheongju-si,
Chungbuk-do, R.O. KOREA

Distributor :

Sep. 2017 printed